

# Emergency Battery Backup Kit

For ST4 and VT models | 120-277V ONLY

## INSTALLATION INSTRUCTIONS



### AC OPERATION

When AC power is on, the LED load from the LED driver is normal power supply. AC LED driver output current can not exceed 150W or 4A. The emergency driver will be charging in standby mode. Green LED light indicates charging.

### EMERGENCY OPERATION

When the AC power goes out, the emergency driver detects the AC power outage and automatically switches to the working emergency mode. The green LED light is off. When the AC power is restored, the emergency driver backs to AC power and starts re-charging, the green LED turns light on.

### FEATURES

- Standard CSA C22.2 NO.141, UL924
- External LiFePO4 battery
- Battery protections: over charge protection, overdischarge protection, short circuit protection
- Indicator shows a variety of working modes
- The batteries meets 500 cycles of standard CH and standard DCH
- RoHS compliant
- Emergency 1.5 hours of operation

### TECHNICAL SPECIFICATIONS

<b>Universal Input Voltage</b>	100-277Vac,50/60Hz
<b>AC Input Current</b>	100mA max.
<b>AC Input Power Rating</b>	7.0W max.
<b>Output Current and Voltage</b>	200-400mA 25-48Vdc
<b>Output Power</b>	8W
<b>Emergency Time</b>	≥1.5H
<b>Full Warranty</b>	5 Years
<b>Test Switch Indicator Light</b>	Illuminated Test Switch, Indicator Light
<b>Battery</b>	LiFePO4 battery-6.4V/3000mAh
<b>Battery Charging Current</b>	250mA
<b>Charging Time</b>	≥24Hours
<b>Temperature Rating (Ambient)</b>	0°C to 50°C (32°F to 122°F)
<b>Dimensions</b>	7.4"x1.5"x1.1"(188mm*38mm*29mm)
<b>Weight</b>	0.83 lbs (0.38kg)

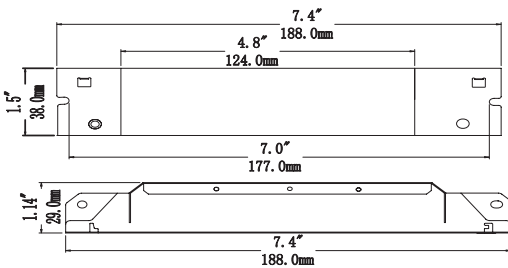

Case: 7.4"x1.5"x1.1"  
(mounting center-7.0")

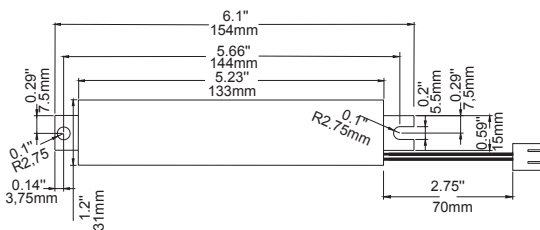

Battery: 6.1"x1.2"  
(mounting center-5.66")

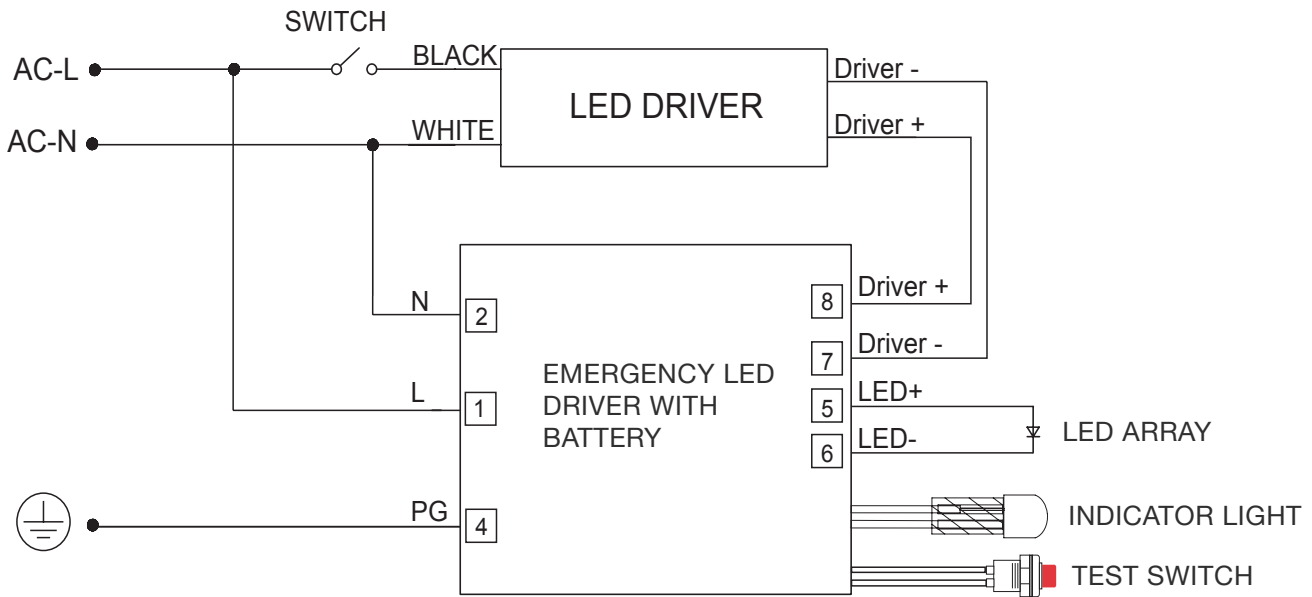

### Wiring Diagram

#### WARNING:

1. DO NOT MATE CONNECTOR UNTIL INSTALLATION IS COMPLETE AND AC POWER IS SUPPLIED.
2. TEST ACCESSORY LEADS-OBSERVE PROPER POLARITY WIRING.

#### READ AND FOLLOW ALL SAFETY INSTRUCTIONS:

- Luminaire wiring and electrical parts may be damaged when drilling for installation of LED Emergency Backup. Check for enclosed wiring and components.
- This product should be installed, inspected, and maintained by a qualified electrician in accordance with all applicable electrical codes.
- Be certain electrical power is OFF before and during installation and maintenance.
- Make sure the supply voltage is the same as the rated luminaire voltage.
- To prevent electrical shock, only mate unit connector after installation is complete and before turn on the AC power
- FOR INDOOR USE ONLY.
- This LED Emergency Backup unit requires an un switched AC power source of 100 277Vac 50 60Hz. The AC driver must be on the same branch circuit as the LED Emergency Backup unit
- Do not let power supply cords touch hot surfaces.
- Do not mount near gas or electric heaters.
- Do not join battery pack connector until all other wiring is complete and AC power is on.
- The Emergency Battery Backup Kit is for use with grounded, ULlisted LED luminaires, shall be enclosed by the LED luminaire and bonded to the grounding of LED luminaire.
- Verify that all replacement lamp types marked on the installed luminaire are also identified as suitable for use with this Emergency Battery Backup Kit.
- The battery pack is fixed by the screw and the indicator lamp is attached to the shell of the luminaire by 3M tape.
- Equipment should be mounted in locations and at heights where it will not be subjected to tampering by unauthorized personnel.
- The use of accessory equipment not recommended by the manufacturer may cause an unsafe condition.
- Do not use this equipment for other than its intended use.
- Use with grounded, UL Listed, dry or damp location rated fixtures.