

2'x2' Panel

20W, 30W, 40W Selectable | 3CCT | 120-347V

High performance, light-weight luminaires suitable for lay-in, surface or pendant mounting. Ideal for use in schools, health care applications, offices, retail spaces, and more

Less than 1.8" Deep
ideal for tight plenum areas

Use Switch to
Select Power
and Colour



0-10V Dimming Lead on Both
Sides of Driver Junction Box

120-347V, 0-10V
Dimmable Driver

Power Selectable
(20W / 30W / 40W)

Waffle Stamping
increases heat
dissipation and
driver life

Seismic Clips
Included



Colour Selectable
(3500K / 4000K / 5000K)



Junction Box (PLS-JB)
sold separately

Accessories (Sold Separately)



Suspension Kit
PLS-SUSKIT

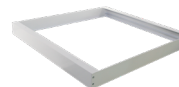

Surface Mount Kit
PLS22-SK



Junction Box
PLS-JB



Recessed Frame Kit
PLS22-RFK

TECHNICAL DATA



LIGHT SPECIFICATIONS

Lumens	4,375 lm
Efficacy	110 lm/W
CCT	3500K/4000K/5000K
CRI	>80
Dimmable	0-10V
Beam Angle	120°
L70 Life	50,000 hrs
Warranty	7-year

	3500K	4000K	5000K
20W	2664 lm	2757 lm	2656 lm
30W	3724 lm	3930 lm	3727 lm
40W	4375 lm	4678 lm	4345 lm

APPROVALS AND LISTINGS

ETL	5000444
DLC	S-UHQD2I

DIMENSIONAL DRAWINGS (IN)

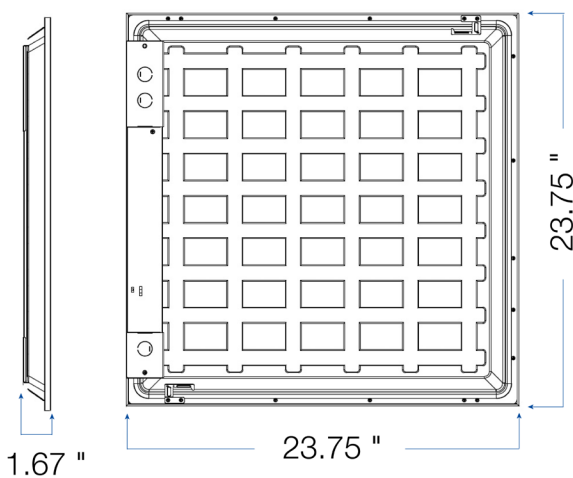

ELECTRICAL

Wattage	Selectable (20W/30W/40W)
Voltage	120-347V
Current	0.44A
Power Factor	0.94
THD	<20 %
Operating Temp	-20 to 40°C

CONSTRUCTION

Housing	Metal
Finish	Polyester Powder Coat
Finish Colour	White
IP Rating	IP20

DIMENSIONS & WEIGHTS

Fixture Weight	4.2 lbs
Fixture Dimensions	23.75" x 1.67" x 23.65"
Carton Qty	4 pcs
Carton Weight	19 lbs
Carton Dimensions	24.7" x 7" x 25"

ACCESSORIES (SOLD SEPARATELY)

PLS22-SK	Surface Mount Kit
PLS22-RFK	Recessed Frame Kit
PLS-SUSKIT	Suspension Kit
PLS-JB	Junction Box