



200W High Bay, HV

Pendant style High Bay with Premium Performance

Optional microwave motion sensor, aluminum reflector, PC reflector, anti-glare kit, and yoke available

Polyester
Powder Coat
Finish

High-impact
tempered glass with
high light transmittance

IP65

Rugged Cast Aluminum

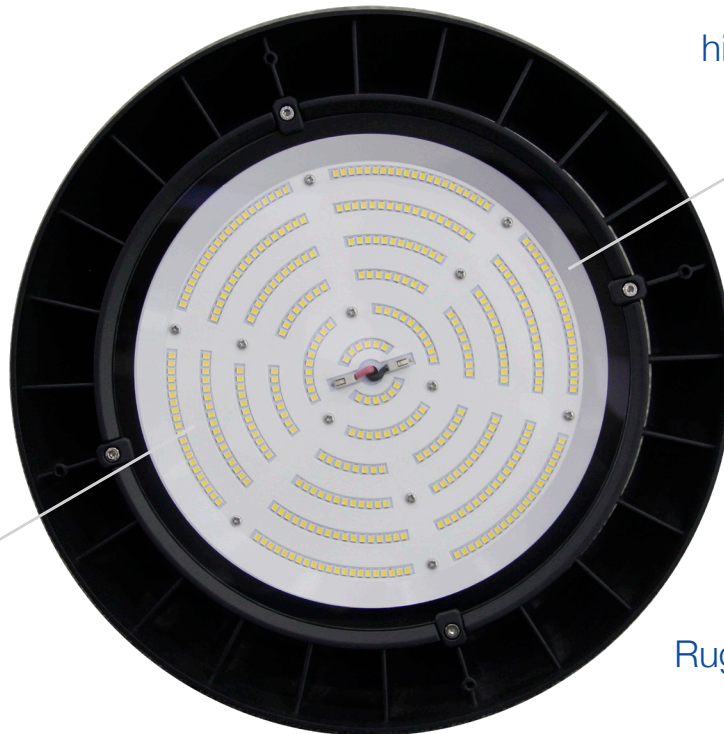

Shown with optional
Dimmable Motion Sensor



Shown with optional
Frosted Polycarbonate
Lens



Shown with optional
Clear Polycarbonate
Lens

0-10V
Dimmable



TECHNICAL DATA



LIGHT SPECIFICATIONS

Lumens	26,960
Efficacy	137.06 lm/W
CCT	5000K
Beam angle	110°
CRI	80
Dimmable	0-10V
Rated hours	50,000
Warranty	5-year

APPROVALS AND LISTINGS

cUL	E482965
DLC PREMIUM	PLT6ZGV6NBG4

DIMENSIONS

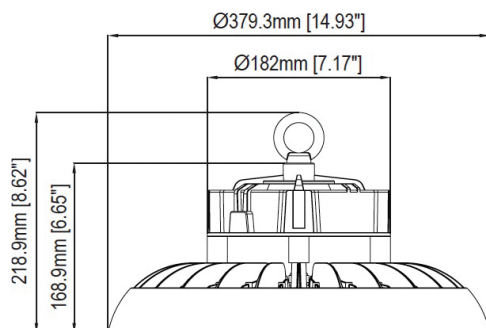

ELECTRICAL

Wattage	200W
Voltage	277-480V
Power factor	0.89
THD	15%
Operating temp	-40 to 40°C

CONSTRUCTION

Housing	Cast Aluminum
Finish	Powder Coat
Colour	Black
IP rating	IP65
Weight	13 lbs
Carton qty	1

INSTALLATION INSTRUCTIONS

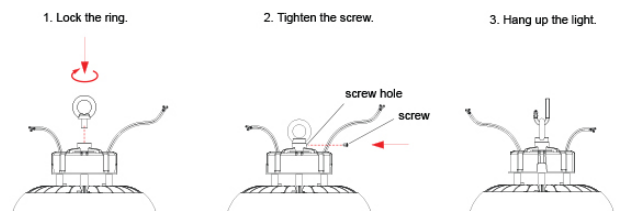

ILLUMINANCE AT A DISTANCE

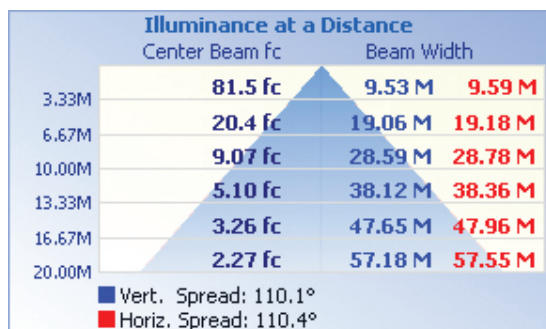

ACCESSORIES

Microwave Motion Sensor Kit	HBP-MMS-KIT
Aluminum Reflector	HBP-AL-REF-B
Anti-glare Kit	HBP-AGK-B
Yoke Mount	HBP-YK-B
Emergency Battery Backup Kit	HBP-EBU
Polycarbonate Frosted Lens	HBP-FR-LENS-B
Polycarbonate Lens	HBP-PC-LENS-B
PC Reflector (200W/240W)	HBP-PC-REF-B