

High Bay

Power Selectable | Colour Selectable | 277-480V

HB8 HIGH BAY

The successor to our best-selling HB7C High Bays!
Ideal for warehouses, factories, gas stations, gymnasiums, grocery stores, food processing facilities, and more



Newly Designed,
Shatterproof
Polycarbonate Optics
meet/exceed DLC 5.1
glare standards

Power Selectable
240W / 270W / 300W

Instant Start and
0-10V Dimmable



Long Life, Elevated Driver
for cooler operation

Colour Selectable
3000K / 4000K / 5000K

Polyester Powder
Coat Finish
black

TECHNICAL DATA



LIGHT SPECIFICATIONS

Lumens*	42,500 lm
Efficacy*	142 lm/W
CCT	3000K / 4000K / 5000K
CRI	>80
Beam Angle	90°
Dimmable	0-10V
L70 Life	50,000 hrs
Warranty	5-year

*Shown at 300W and 3000K

APPROVALS & LISTINGS

cUL	E482965
-----	---------

DIMENSIONS AND WEIGHTS

Fixture Weight	8.9 lbs
Fixture Dimensions	15.4 x 15.4 x 8.8 in
Carton Qty	1
Carton Weight	10.8 lbs
Carton Dimensions	17.7 x 17.7 x 7.9 in

DIMENSIONAL DRAWINGS

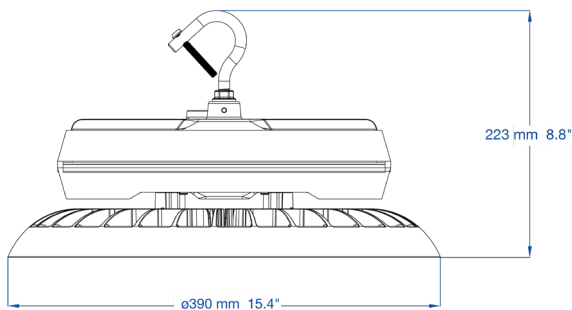

ELECTRICAL

Wattage	240W / 270W / 300W
Voltage	277-480V
Current	1.90A
Surge Protection	6kV
Auxiliary Output	12V
Power Factor	≥0.9
THD	≤20%
Operating Temp	-40 to 50°C

CONSTRUCTION

Housing	Die-Cast Aluminum
Lens	Polycarbonate
Finish	Powder Coated
Finish Colour	Black
IP Rating	IP65

ACCESSORIES (Ordered Separately)

Polycarbonate Reflector	HB8-PC-REF-XL
Polycarbonate Cover	HB8-PC-REF-XL-BCV
Aluminum Reflector	HB8-AL-REF-XL
Wire Guard	HB8-WG-XL
Yoke Mount	HB8-YK-XL
Microwave Sensor	HB01DMS-A
Infrared Motion Sensor	MS01-PIR-TW-DC
Motion Sensor Remote	HB01R
Frosted Lens	HB8-FR-LENS-XL
120° Optics	HB8-120D-LENS-XL
60° Optics	HB8-60D-LENS-XL
Eye Bolt	HB8-EB

NOTE: **HB01R** is **required** for the **HB01DMS-A** and **MS01-PIR-TW-DC** to function