

# High Bay

Power Selectable | Colour Selectable | 120-347V

## HB8 HIGH BAY

The successor to our best-selling HB7C High Bays!  
Ideal for warehouses, factories, gas stations, gymnasiums, grocery stores, food processing facilities, and more

Newly Designed,  
Shatterproof  
Polycarbonate Optics  
meet/exceed DLC 5.1  
glare standards



NEMA 4X



Power Selectable  
200W / 220W / 240W

Instant Start and  
0-10V Dimmable

Complete with 6'  
Cord Whip



Long Life, Elevated Driver  
for cooler operation

Colour Selectable  
3000K / 4000K / 5000K

Polyester Powder  
Coat Finish  
black

## TECHNICAL DATA



### LIGHT SPECIFICATIONS

|            |                       |
|------------|-----------------------|
| Lumens*    | 33,267 lm             |
| Efficacy*  | 137 lm/W              |
| CCT        | 3000K / 4000K / 5000K |
| CRI        | 81                    |
| Beam Angle | 90°                   |
| Dimmable   | 0-10V                 |
| L70 Life   | 50,000 hrs            |
| Warranty   | 5-year                |

\*Shown at 240W and 3000K

### APPROVALS & LISTINGS

|             |          |
|-------------|----------|
| cUL         | E482965  |
| DLC Premium | S-NSK8ZH |

### DIMENSIONS AND WEIGHTS

|                    |                      |
|--------------------|----------------------|
| Fixture Weight     | 6.83 lbs             |
| Fixture Dimensions | 11 x 11 x 7.3 in     |
| Carton Qty         | 1                    |
| Carton Weight      | 7.94 lbs             |
| Carton Dimensions  | 13.4 x 13.4 x 7.3 in |

### DIMENSIONAL DRAWING

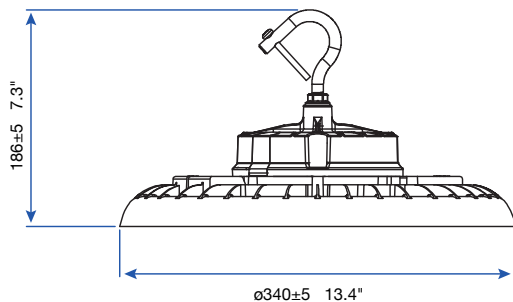

### ELECTRICAL

|                  |                    |
|------------------|--------------------|
| Wattage          | 200W / 220W / 240W |
| Voltage          | 120-347V           |
| Current          | 2.70A              |
| Surge Protection | 6kV                |
| Auxiliary Output | 12V                |
| Power Factor     | 0.9                |
| THD              | 15%                |
| Operating Temp   | -40 to 50°C        |

### CONSTRUCTION

|               |                   |
|---------------|-------------------|
| Cord Whip     | 6'                |
| Housing       | Die-Cast Aluminum |
| Lens          | Polycarbonate     |
| Finish        | Powder Coated     |
| Finish Colour | Black             |
| IP Rating     | IP65              |

### ACCESSORIES (Ordered Separately)

|                         |                   |
|-------------------------|-------------------|
| Polycarbonate Reflector | HB8-PC-REF-LG     |
| Polycarbonate Cover     | HB8-PC-REF-RG-BCV |
| Aluminum Reflector      | HB8-AL-REF-LG     |
| Wire Guard              | HB8-WG-LG         |
| Yoke Mount              | HB8-YK-LG         |
| Microwave Sensor        | MS04-MW-TW-DC     |
| Infrared Motion Sensor  | MS01-PIR-TW-DC    |
| Motion Sensor Remote    | HB01R             |
| Frosted Lens            | HB8-FR-LENS-LG    |
| 120° Optics             | HB8-120D-LENS-LG  |
| 60° Optics              | HB8-60D-LENS-LG   |
| Safety Cable            | HB8-CABLE         |
| Eye Bolt                | HB8-EB            |

NOTE: **HB01R** is **required** for the **HB01DMS-A** and **MS01-PIR-TW-DC** to function