

# High Bay

Power Selectable | Colour Selectable | 120-347V

## HB8 HIGH BAY

The successor to our best-selling HB7C High Bays!  
Ideal for warehouses, factories, gas stations, gymnasiums, grocery stores, food processing facilities, and more

Newly Designed,  
Shatterproof  
Polycarbonate Optics  
meet/exceed DLC 5.1  
glare standards



Power Selectable  
60W / 80W / 100W

Complete with 6'  
Cord Whip

Instant Start and  
0-10V Dimmable



Long Life, Elevated Driver  
for cooler operation

Colour Selectable  
3000K / 4000K / 5000K

Polyester Powder  
Coat Finish  
black

## TECHNICAL DATA



### LIGHT SPECIFICATIONS

Lumens*	13,587 lm
Efficacy*	135 lm/W
CCT	3000K / 4000K / 5000K
CRI	82
Beam Angle	90°
Dimmable	0-10V
L70 Life	50,000 hrs
Warranty	5-year

\*Shown at 100W and 3000K

### APPROVALS & LISTINGS

cUL	E482965
DLC	S-7BRI00

### DIMENSIONAL DRAWINGS

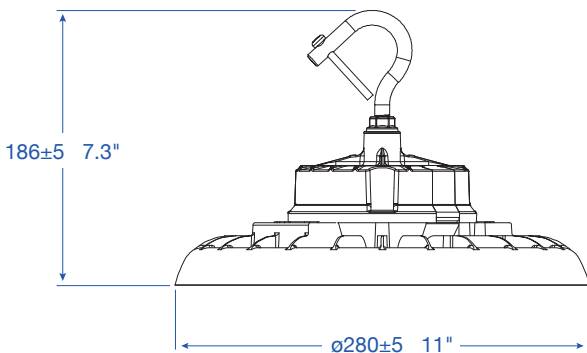

### ILLUMINANCE AT A DISTANCE

Distance (ft)	Illuminance at a Distance	
	Center Beam fc	Beam Width
17.0ft	22.8 fc	33.2 ft 34.2 ft
34.0ft	5.7 fc	66.3 ft 68.4 ft
51.0ft	2.5 fc	99.5 ft 102.6 ft
68.0ft	1.4 fc	132.6 ft 136.8 ft
85.0ft	0.9 fc	165.8 ft 171.0 ft
102.0ft	0.6 fc	198.9 ft 205.2 ft

■ Vert. Spread: 88.6°  
■ Horiz. Spread: 90.3°

### ELECTRICAL

Wattage	60W / 80W / 100W
Voltage	120-347V
Current	1.20A
Surge Protection	6kV
Auxiliary Output	12V
Power Factor	0.9
THD	15%
Operating Temp	-40 to 50°C

### CONSTRUCTION

Cord Whip	6'
Housing	Die-Cast Aluminum
Lens	Polycarbonate
Finish	Powder Coated
Finish Colour	Black
IP Rating	IP65

### DIMENSIONS AND WEIGHTS

Fixture Weight	4.85 lbs
Fixture Dimensions	11 x 11 x 7.3 in
Carton Qty	1
Carton Weight	5.95 lbs
Carton Dimensions	11.8 x 11.8 x 4.9 in

### ACCESSORIES (Ordered Separately)

Polycarbonate Reflector	HB8-PC-REF-SM
Polycarbonate Cover	HB8-PC-REF-SM-BCV
Aluminum Reflector	HB8-AL-REF-SM
Wire Guard	HB8-WG-SM
Yoke Mount	HB8-YK-SM
Microwave Sensor	HB01DMS-A
Motion Sensor Remote	HB01R
Frosted Lens	HB8-FR-LENS-SM
120° Optics	HB8-120D-LENS-SM
60° Optics	HB8-60D-LENS-SM
Safety Cable	HB8-CABLE

HEAD OFFICE: 8 - 540 Jamieson Pkwy, Cambridge, ON, N3C 0G5 | orders@csc-led.com | (519) 880 - 9833