

EXPL Linear Explosion-Proof

Suitable for Class 1, Division 2, (Group A, B, C, D) environments or lower.
NOT SUITABLE FOR CLASS 1, DIVISION 1 APPLICATIONS

WARNING: Ensure power is off before installation, wiring, or performing any maintenance on the fixture.

WIRING DIAGRAM & INSTRUCTIONS

1. Constant current can be achieved by 1-10VDC dimming, PWM signal dimming, (Dimming wire for 1-10 VDC or PWM signal dimming should be connected to the terminal block in fixture through a suitable conduit; Check the label next to terminal block for the polarity of wire)
2. Choose the appropriate dimming according to your needs. You can also opt-out of using this function.
3. Loosen the screws on the driver box cover (Fig 1).
4. Open the cover and let it hang on the retention cable (Fig. 2).
5. Unscrew the 3/4" NPT nut and install a suitable conduit to the conduit opening. Pull the wire through the conduit hole (Fig. 2), and connect it to the 5PIN terminal block. The wire connected to the terminal block should be aluminum or copper conductors. Connectors should be secured by Torque: 4.4 in-lbs. See the label at the terminal block for wiring.
6. Lock the driver box cover with screws (Fig. 3).

Note: All the conduit openings must be closed by conduit or NPT nut. Whenever installing the NPT nut or conduit during installation or maintenance, ensure silicone gel is added around the threads (Fig. 5).

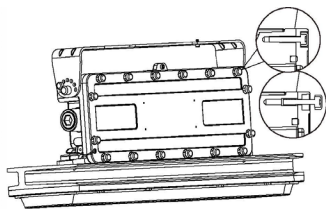

Fig. 1

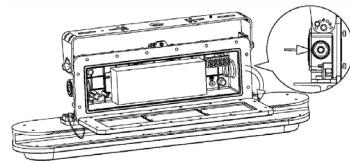

Fig. 2

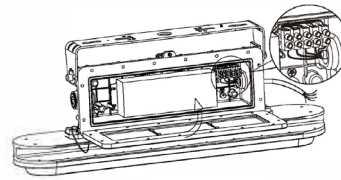

Fig. 3

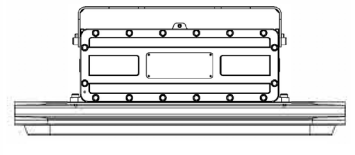

Fig. 4

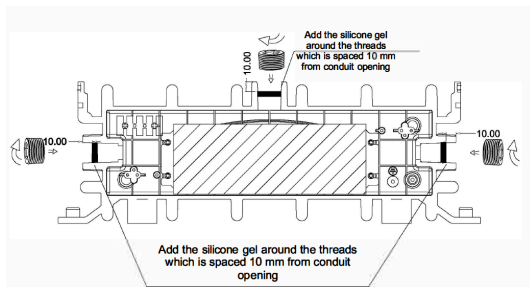

Fig. 5

BRACKET WALL MOUNTING

1. Mark the wall and drill as appropriate. (Fig. 5).
2. Use a hammer to put the expansion screws into the holes (Fig. 6).
3. Install the expansion shields in the wall (Fig. 7).
4. Tighten the nut of the screws (Fig. 8).
5. Hang the fixture into the lifting hook or chain and protect it from falling (Fig. 9).
6. Wiring according to the instructions on the first and second pages.
7. After installation, connect power supply wires in accordance with local codes/standards. Ensure all joints, threads and conduits are adequately sealed. Users can adjust 30°-60°-90° to left or right from vertical downward direction by adjusting the screw on the bracket (Fig. 10).

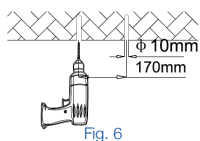

Fig. 6

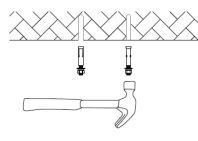

Fig. 7

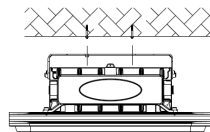

Fig. 8

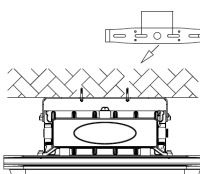

Fig. 9

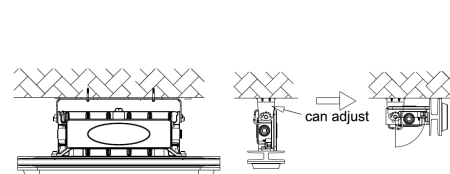
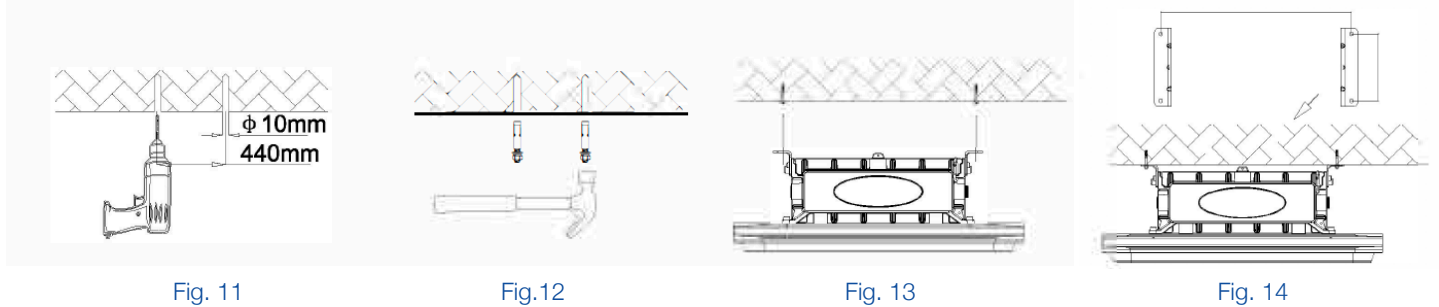

Fig. 10

CEILING MOUNTING

1. Mark the ceiling and drill as appropriate (Fig. 11).
2. Install expansion shields in holes (Fig. 12).
3. The holes on the bracket should be aligned with the expansion screws, then push the fixture to one side (Fig. 13).
4. Tighten the nut of the screws (Fig. 14).
5. Wire in accordance with the instructions on the first and second pages.



NOTES:

- A. Can be equipped for 4 sizes of U-bolts. The sizes are as follows: 21mm, 27mm, 48mm, 60mm (Fig. 15).
- B. Select the appropriate bolts (Fig. 15), assemble the bolts to the fixture, and install the nuts (Fig. 16).
- C. Insert the U-shaped bolt of the fixture into the round pipe (Fig. 17); tighten the bolt M6 nut, and the other M4 hex screw from the bottom of the bracket to fix the round rod (Fig. 18).
- D. Wire guard is optional and can be installed according to the application (Fig. 18).
- E. Wire in accordance with the instructions on the first and second pages.

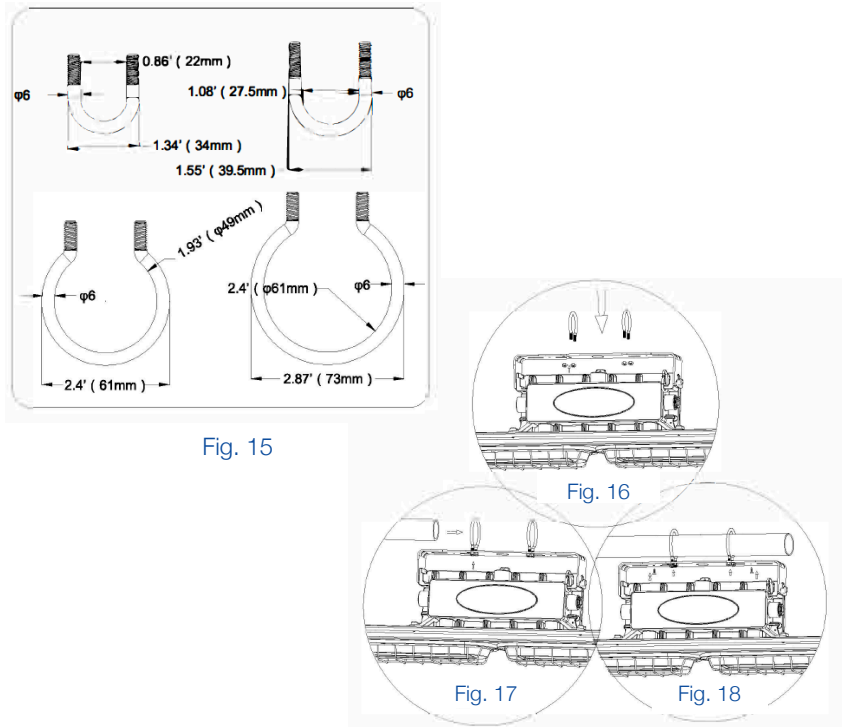

HANGING CHAIN MOUNTING

1. There are pre-installed rings or hooks to hang the chain hook.
2. Hang the fixture into the lifting hook or chain (Fig. 19) (Fig. 20).
3. After installation, wire in accordance with local connection standard, and implement waterproof measures at the joint of conduit.

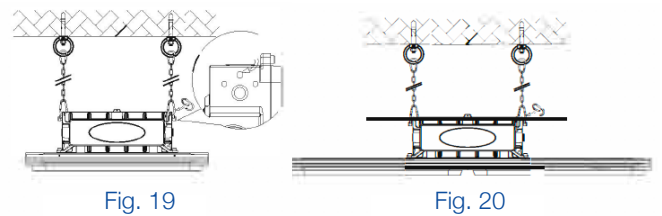

THREADED PIPE MOUNTING

1. Remove the threaded plug (Fig. 21).
2. Pass the wire in the threaded pipe through the hole and connect to the wire of the terminal accordingly (Fig. 22).
3. After the wiring is completed, put the threaded pipe into the hole and turn it clockwise to tighten. Then tighten the nearby fixing screw and hold it against the threaded pipe (Fig. 22).
4. Lock the driver box cover with screws (Fig. 23).
5. After installation, wire according to local codes. Seal all joints, threads and conduit as needed.

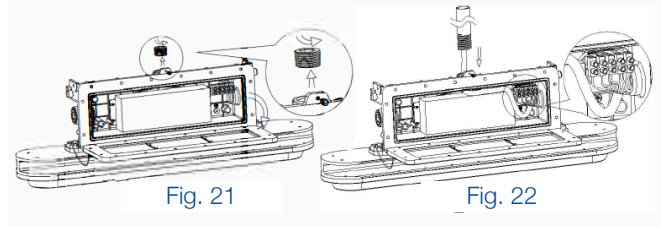

Fig. 21

Fig. 22

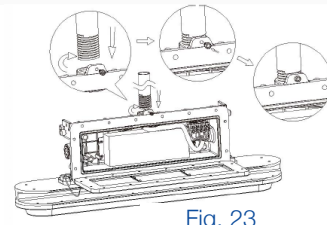

Fig. 23

WIREGUARD INSTALLATION (OPTIONAL)

1. There are already 8 M3 screw holes on the cover of the fixture (Fig. 24).
2. Before installing the fixture, put a wire guard on the fixture cover (Fig. 25).
3. Secure the wire guard with screws (Fig. 26).

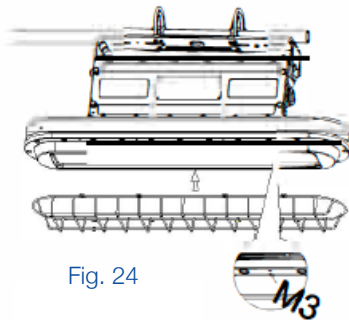

Fig. 24

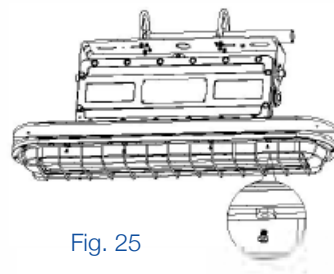

Fig. 25

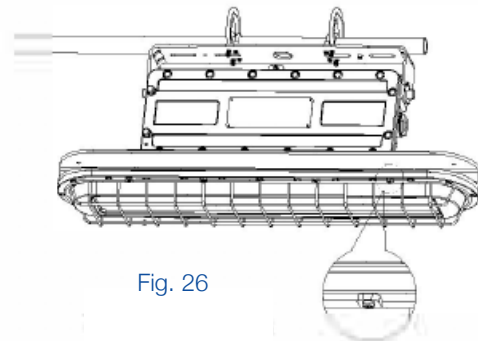

Fig. 26

SECOND-RETENTION POINT

1. Wire rope is necessary for the 40W/80W/120W fixture (Fig. 27).
2. Surround the wire rope to the wire rope fixing position in the middle of the fixture. (Fig. 28).
3. Fasten the other end of the wire rope to the outlet box or the mounting structure of the outlet box. (Fig. 29).



Fig. 27

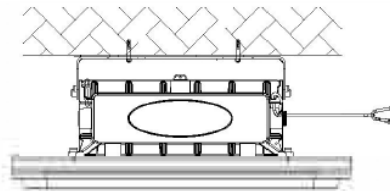

Fig. 28

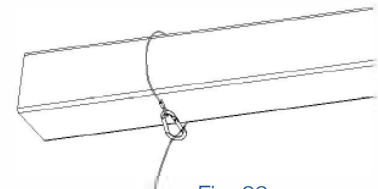

Fig. 29

WARNING: MIN 90°C SUPPLY CONDUCTORS. THIS PRODUCT MUST BE INSTALLED IN ACCORDANCE WITH THE APPLICABLE INSTALLATION CODE BY A PERSON FAMILIAR WITH THE CONSTRUCTION AND OPERATION OF THE PRODUCT AND THE HAZARDS INVOLVED. **AVERTISSEMENT:** LES FILS D'ALIMENTATION 90°C MIN. CE PRODUIT DOIT ETRE INSTALLE SELON LE CODE D'INSTALLATION PERTINENT, PAR UNE PERSONNE QUI CONNAIT BIEN LE PRODUIT ET SON FONCTIONNEMENT AINSI QUE LES RISQUES INHERENTS.