

AWP04 Architectural Wall Pack

Power Selectable | 3CCT | 120-347V

Meet the successor to our AWP03 series Wall Packs, **now power and colour selectable!**
Ideal for building entrances, multi-use facilities, apartment buildings, institutions, schools, and more

Power Selectable
50W/60W/70W/80W

Adjustable 0-90°
for precise aiming



Colour Selectable
3000K/4000K/5000K

Durable Die-Cast
Aluminum Housing

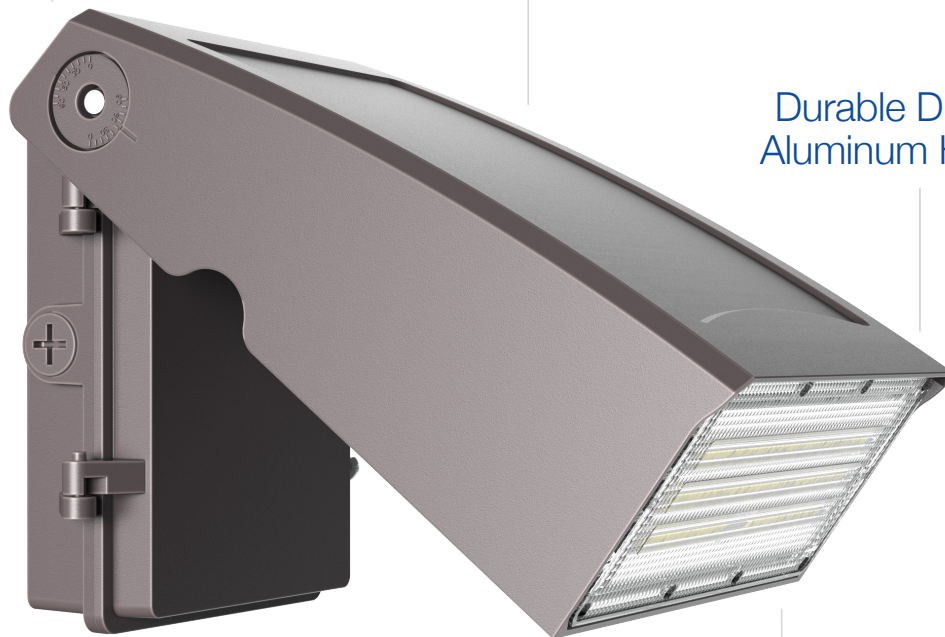

Standard Junction
Box Mount
with facility for photocell
(sold separately)

Built-in Water
Drainage

UV-Resistant Polycarbonate
Refractor Lens
with Type II distribution

TECHNICAL DATA



LIGHT SPECIFICATIONS

Lumens	9,966 lm
Efficacy	124.86 lm/W
CCT	3000K/4000K/5000K
CRI	72
Dimmable	0-10V
L70 Life	50,000 hrs
Warranty	10-year

APPROVALS AND LISTINGS

cETL	5018387
DLC Premium	S-BYZP7D

ISOCANDELA PLOT

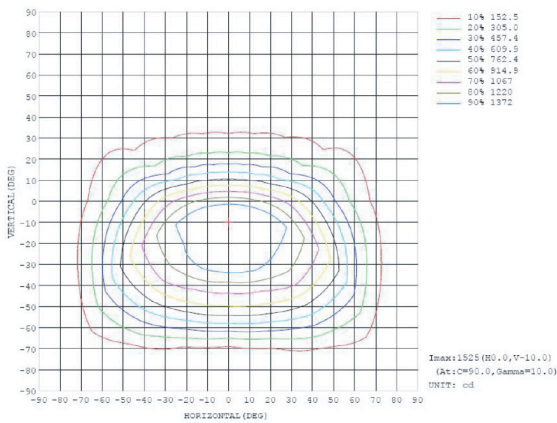

LUMINOUS INTENSITY DISTRIBUTION

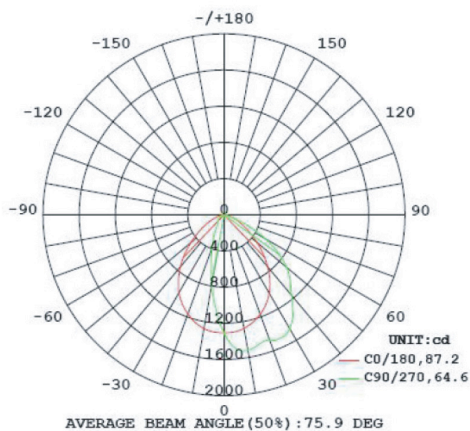

ELECTRICAL

Wattage	50W/60W/70W/80W
Voltage	120-347V
Current	1.05A
Power Factor	0.934
THD	12.1%
Operating Temp	-30 to 45°C

CONSTRUCTION

Housing	Die-Cast Aluminum
Lens	Polycarbonate
Finish	Bronze
IP Rating	IP65
Net Weight	3.13 kg
Gross Weight	3.73 kg
Carton Qty	1
Master Carton Dimensions	375 x 295 x 180 mm

DIMENSIONS

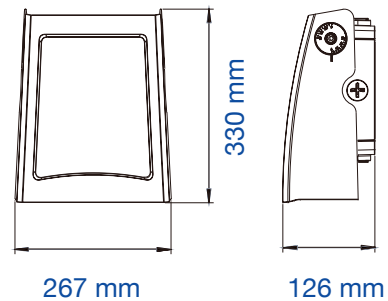

SPECTRORADIOMETRIC PARAMETERS

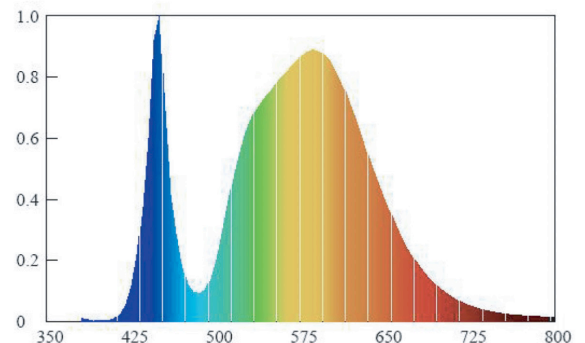

Western Canada Warehouse: 121-1647 Broadway Street, Port Coquitlam, BC V3C 6P8 | ordersbc@csc-led.com