

WARNINGS



RISK OF FIRE, ELECTRICAL SHOCK, CUTS OR OTHER CASUALTY HAZARDS

Installation and maintenance of this product must be performed by a qualified electrician. This product must be installed in accordance with the applicable installation code by a person familiar with the construction and operation of the product and hazards involved.

RISK OF FIRE AND ELECTRIC SHOCK

Make certain power is OFF before starting installation or attempting any maintenance. Disconnect power at fuse or circuit breaker.

RISK OF FIRE

Refer to product label for specific minimum supply conductor requirements.

RISK OF BURN

Disconnect power and allow fixture to cool before handling or servicing.

RISK OF PERSONAL INJURY

Fixture may become damaged and/or unstable if not installed properly.

DISCLAIMER OF LIABILITY: CSC LED assumes no liability for damages or losses of any kind that may arise from the improper, careless, or negligent installation, handling or use of this product.

NOTICE: Green ground wire is provided in proper location. Do not relocate.

SAFETY: This fixture must be wired in accordance with the National Electrical Code and applicable local codes and ordinances. Proper grounding is required to ensure personal safety. Carefully observe grounding procedure under installation section.

APPLICATIONS: This lighting fixture is designed for indoor lighting applications, and should not be used in an area with limited ventilation or inside high ambient temperature enclosures. It must be stored in a dry location prior to installation.

ATTENTION RECEIVING DEPARTMENT: Note actual fixture description of any shortage or noticeable damage on delivery receipt. File claim for common carrier (LTL) directly with carrier. Claims for concealed damage must be filed within 15 days of delivery. All damaged material, complete with original packaging must be retained.

RECESSED KIT MOUNT

(NOT APPLICABLE FOR CONTINUOUS ROW MOUNT)

1. Remove the lens and LED reflector strip. (Fig. 1)
2. Cut a rectangular hole in the mounting surface. (Fig. 2)
3. Install the rivet nuts with a rivet nut setter (*not provided*). (Fig. 3)
4. Install the flange bars on the fixture. (Fig. 4)
5. Install the brackets on the fixture. (Fig. 5)
6. Push the fixture into the mounting surface until it is secured. Adjust the wing screws to further secure the fixture and remove any potential gap. (Fig. 6)

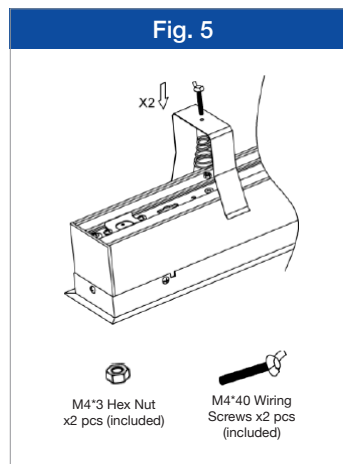
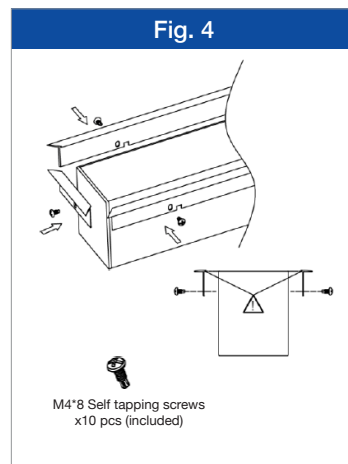
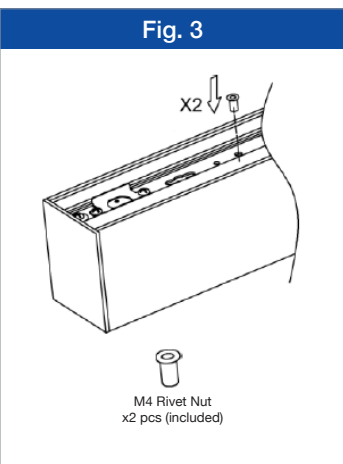
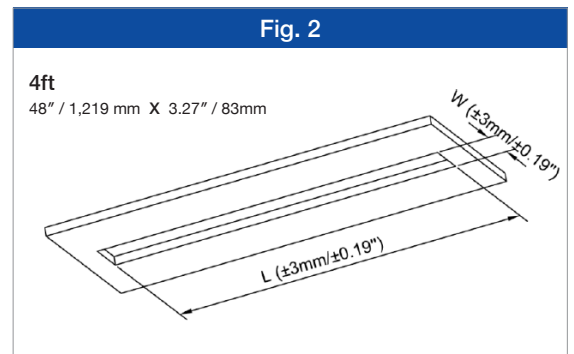
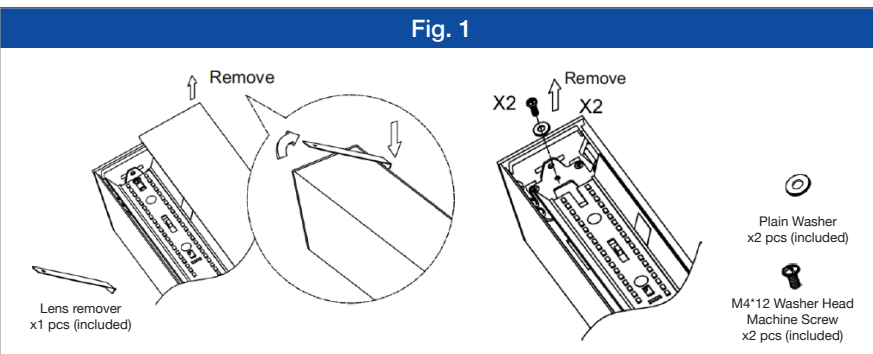

MUD-IN RECESSED MOUNT

(FOR INSTALLATION WITHOUT UPLIGHT MODULE)

1. Remove lens and LED reflector strip. Secure the provided aircraft cable grippers with screws and split washers (See luminaire instructions for more details). (Fig. 1)

NOTE: Aircraft cables **must** be installed. CSC LED is not liable for any damage caused if cables are not installed.

2. Cut a rectangular hole on the mounting surface. (Fig. 2)

3. Install the mud-in bars on the fixture. (Fig. 3)

4. Lift fixture to approximately 12 inches below the ceiling.

Connect power cable (refer to wiring diagram) and secure the cable with strain relief. (Fig. 4)

5. Trim excess aircraft cable. Push the fixture into the ceiling and secure it with the provided hardware. The LED reflector strip and lens may now be reinstalled. (Fig. 5)

6. Apply desired material (not provided) to cover the mud-in bars. (Fig. 6)

Fig. 1

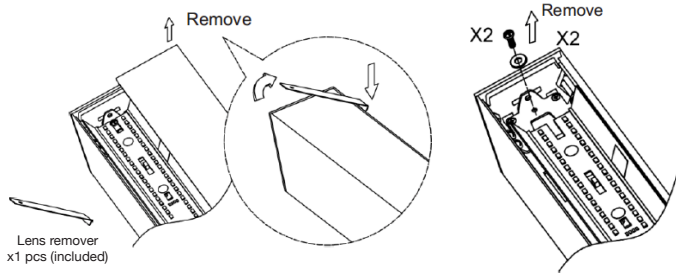

Fig. 2

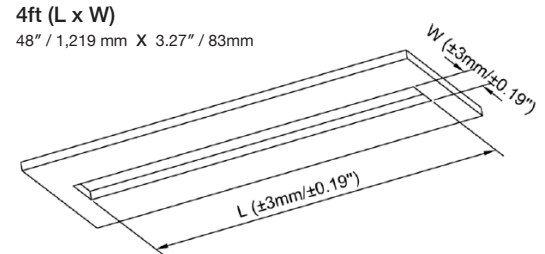

Fig. 3

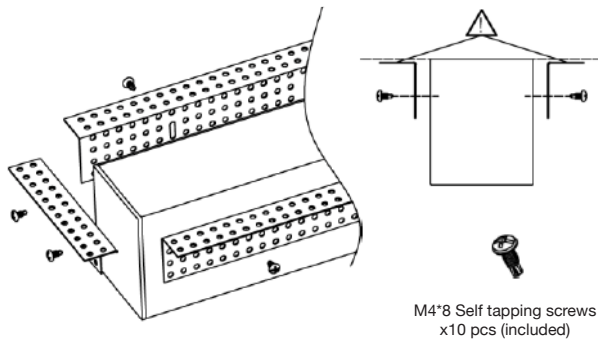

Fig. 4

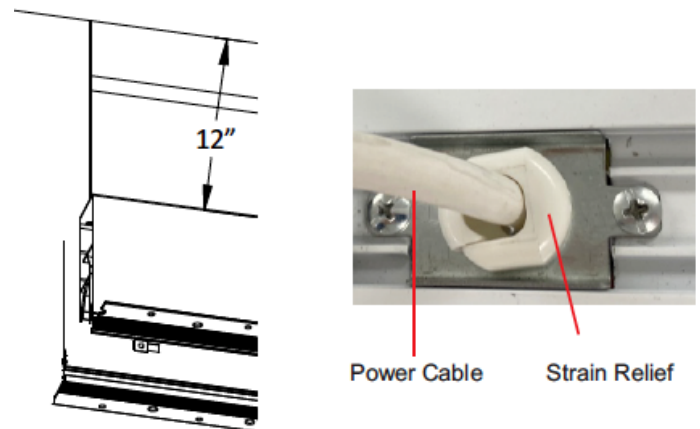

Fig. 5

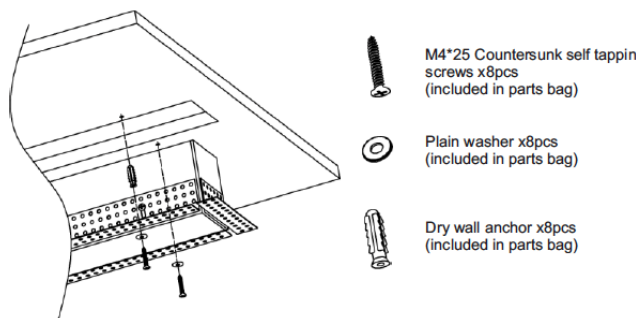
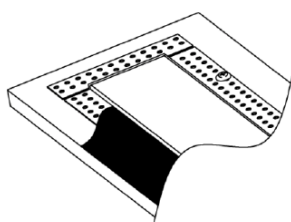
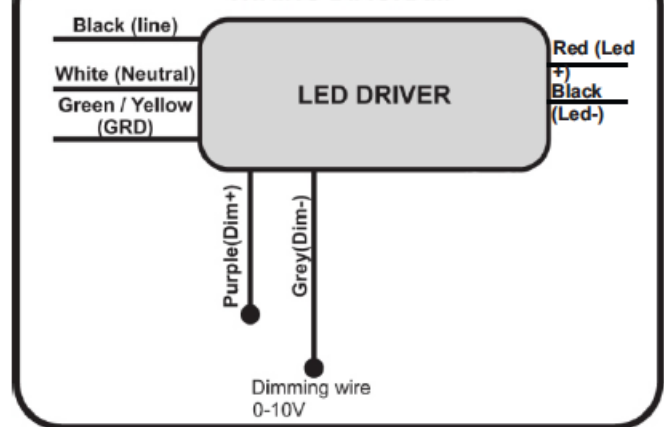

Fig. 6



WIRING DIAGRAM



FOR CONTINUOUS ROW MOUNT

Install connection kits and screws to connect fixtures as per continuous row mount and corner connectors' section in the included installation instructions.

Then follow the Mud-In Recessed Kit instructions to complete. **Do not** install the shorter end pieces between every 2 fixtures.

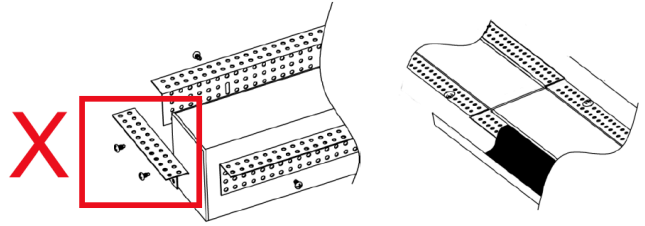

Install all 8pcs of screws for each 4ft fixture.
The minimum mounting points required for every 2 or more fixtures are as below:

Qty of Fixtures in a Row	Min. Required Mounting Points
2	16
4	32
6	48

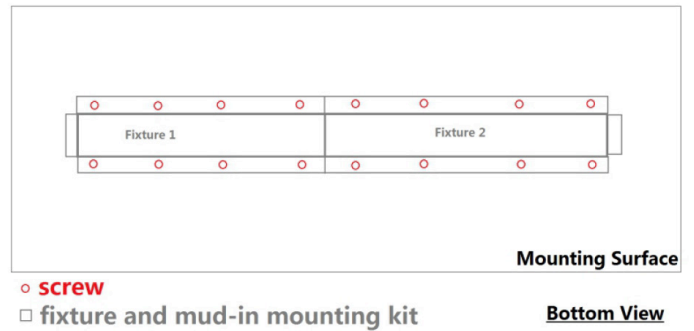

Questions or Concerns? We are happy to help!

Email Us: info@csc-led.com

Call Us: 1-888-900-9885