

WARNINGS



RISK OF FIRE, ELECTRICAL SHOCK, CUTS OR OTHER CASUALTY HAZARDS

Installation and maintenance of this product must be performed by a qualified electrician. This product must be installed in accordance with the applicable installation code by a person familiar with the construction and operation of the product and hazards involved.

RISK OF FIRE AND ELECTRIC SHOCK

Make certain power is OFF before starting installation or attempting any maintenance. Disconnect power at fuse or circuit breaker.

RISK OF FIRE

Refer to product label for specific minimum supply conductor requirements.

RISK OF BURN

Disconnect power and allow fixture to cool before handling or servicing.

RISK OF PERSONAL INJURY

Fixture may become damaged and/or unstable if not installed properly.

DISCLAIMER OF LIABILITY: CSC LED assumes no liability for damages or losses of any kind that may arise from the improper, careless, or negligent installation, handling or use of this product.

NOTICE: Green ground wire is provided in proper location. Do not relocate.

SAFETY: This fixture must be wired in accordance with the National Electrical Code and applicable local codes and ordinances. Proper grounding is required to ensure personal safety. Carefully observe grounding procedure under installation section.

APPLICATIONS: This lighting fixture is designed for indoor lighting applications, and should not be used in an area with limited ventilation or inside high ambient temperature enclosures. It must be stored in a dry location prior to installation.

ATTENTION RECEIVING DEPARTMENT: Note actual fixture description of any shortage or noticeable damage on delivery receipt. File claim for common carrier (LTL) directly with carrier. Claims for concealed damage must be filed within 15 days of delivery. All damaged material, complete with original packaging must be retained.

DIMENSIONAL DRAWING

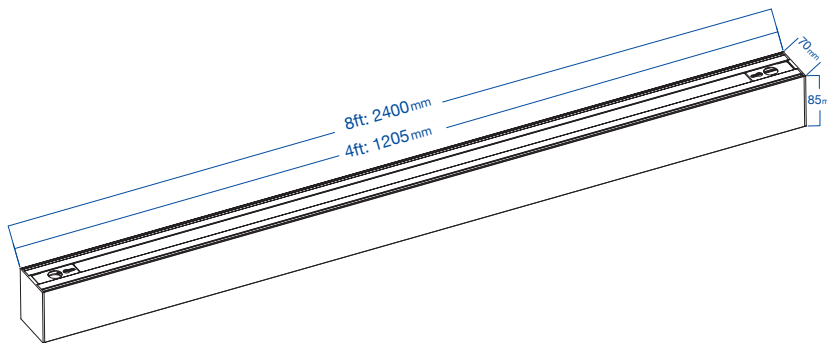

WIRING DIAGRAM

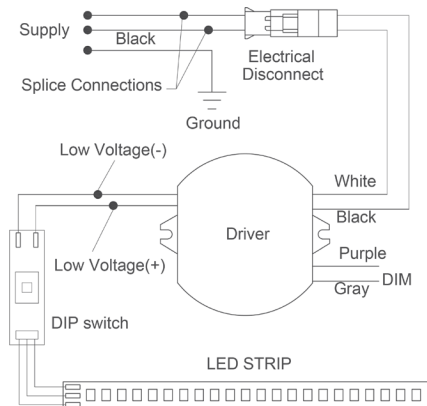

SURFACE MOUNT

(NOT COMPATIBLE WITH UPLIGHT MODULE)

1. Remove the lens with the tool provided and then remove the LED reflector strip. (Fig. 1, 2)
2. Mount the fixture with screws and anchors (not included) through the pre-drilled holes on the top of the fixture. (Fig. 3)
3. Connect the power cord (refer to wiring diagram) and secure the power cable with the included strain relief. (Fig. 4)
4. Select CCT (30K/35K/40K) and replace the reflector and lens (Fig. 5, 6)

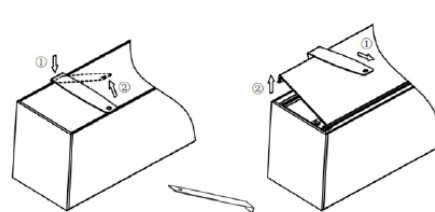

Fig. 1

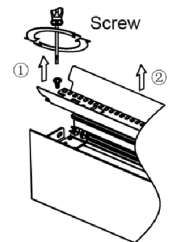
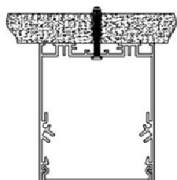

Fig. 2



Drywall

Fig. 3



Power Cable Strain Relief

Fig. 4

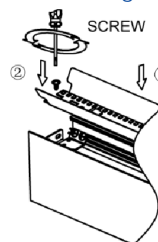

Fig. 5

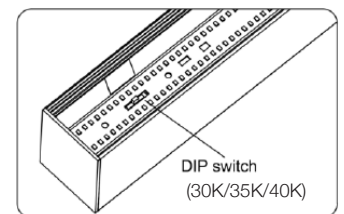

Fig. 6

SUSPENDED MOUNT

(FOR INSTALLATION WITHOUT UPLIGHT MODULE)

1. Remove lens and LED reflector strip (see *Surface Mount instructions*). Secure aircraft cable grippers with screws and washers in the provided holes on the top of the fixture. (Fig. 7)
2. Remove the power cord knockout and connect the power cord to the ceiling power feed using the included strain relief (refer to wiring diagram). (Fig. 8)

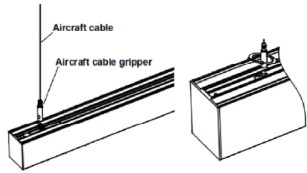

Fig. 7

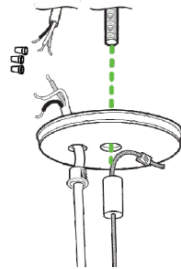

Fig. 8

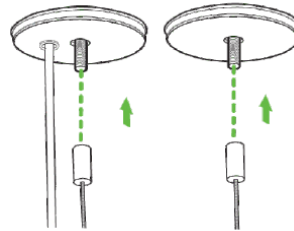

Fig. 9

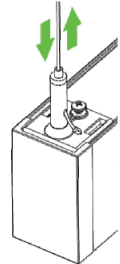

Fig. 10

3. Place canopies in proper position and tighten the aircraft cable couplings. (Fig. 9)
4. Adjust the aircraft cable to achieve desired mounting height. Cut excessive cable if necessary. (Fig. 10)
5. Select CCT (30K/35K/40K) and replace the reflector and lens. (Fig. 6)

SUSPENDED MOUNT

FOR INSTALLATION WITH UPLIGHT MODULE)

1. Remove lens and LED reflector strip (see *Surface Mount instructions*). Loosen the screws to remove end cap. (Fig. 11)
2. Remove the access plate (**Warning:** only tighten the screws after removing the access plate from the fixture housing). (Fig. 12)
3. Slide and securely tighten the screws (with washer) onto the access plate. Install the end cap back in place. (Fig. 13)
4. Remove the power cord knockout and connect the power cord to the ceiling power feed using the supplied strain relief (Refer to wiring diagram). (Fig. 8)

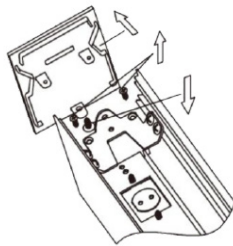

Fig. 11

5. Place canopies in proper position and tighten the aircraft cable. (Fig. 9)
6. Adjust the aircraft cable to achieve desired mounting height. Cut excessive cable if necessary. (Fig. 10)
7. Select CCT (30K/35K/40K) and replace the reflector and lens. (Fig. 6)

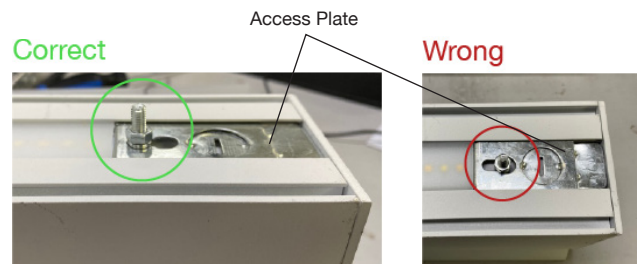

Fig. 12

Correct



Correct



Washer

Fig. 13

NOTE: All fixtures and corner pieces are marked with an **A** on one end and a **B** on the other end.
In all cases **A**'s must be connected to **B**'s

1. Remove lens and LED reflector strip. Loosen the screws to remove end cap. (Fig. 14)
2. Insert the connection kit on the end of the fixture. Connect it with the supplied screws. (Fig. 15)
3. Connect the electrical wires (refer to the wiring diagram), slide the fixtures and or corner connectors together (A to B). Join the connection kit, centering it between the fixtures and or corner connectors, and put the remaining screw in place. (Fig 16)

4. Replace the LED reflector strips and screw them back onto the plates. (Fig. 17)
5. Screw the end plates from the hole on plate A (flat top) to the hole on plate B (round top). (Fig. 18)
6. Select CCT (30K/35K/40K) (Fig. 6)
7. Put the lens back in place. Adjust the lens to cover the potential gap in the middle. (Fig. 19)

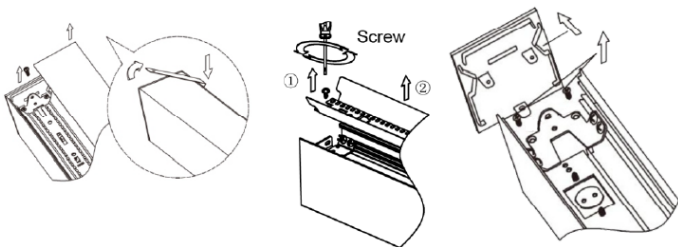

Fig. 14

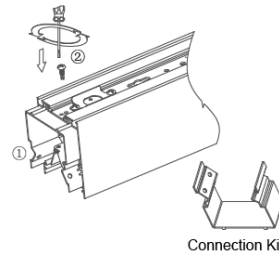

Fig. 15

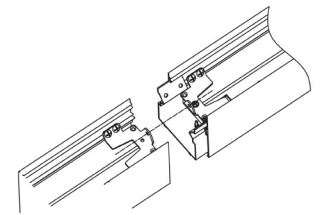

Fig. 16

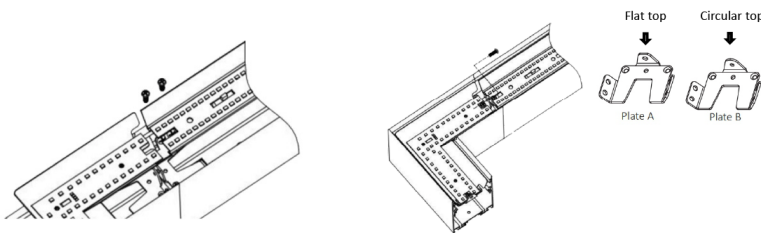

Fig. 17

Fig. 18

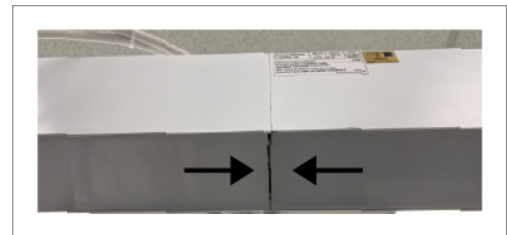
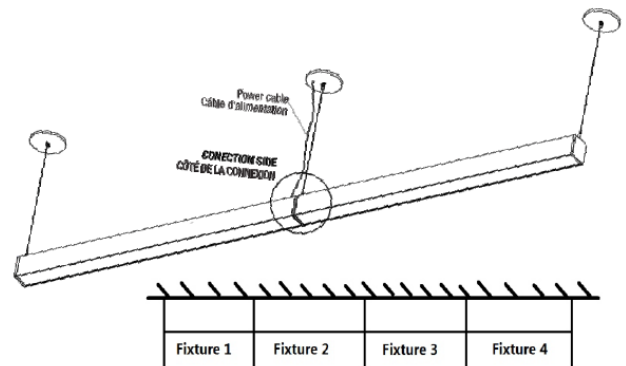

Fig. 19

The minimum mounting points required for every two or more fixtures are as listed.

Qty of Fixtures in a Row	Min. Required Mounting Points
2	3
4	5
6	7



For additional installation instructions regarding the *Mud In Recessed Kit* (AL-MR-KIT) and the *Recessed Kit* (AL-R-KIT) please visit our website at www.csc-led.com